

Press Release

Systel awarded key patent for breakthrough power topologies for innovative electronic ballast and luminaries systems

Nes Tziona, Israel, October 24, 2006 - Systel Development and Industries Ltd., a mixed-signal semiconductor company that provides digital SoC - System-on-Chip - power control and management controllers solutions for the power conversion industry was granted patent number 7,009,348 by the United States Patent and Trademark Office for Systel's unique multiple channel ballast topologies and solutions enabled by Systel's IDC2000 - Integrated Digital Controller - SoC platform. A more extended patent application on this subject was also filed in Europe.

This patent is in addition to the US patent number 6,946,984 granted previously for the IDC2000 platform architecture.

This multi-channel ballast topology patent covers a very wide range of solutions starting from single dimmable and non-dimmable ballasts for multi lamp lighting to central ballasts to control several luminaries with different types of lamps.

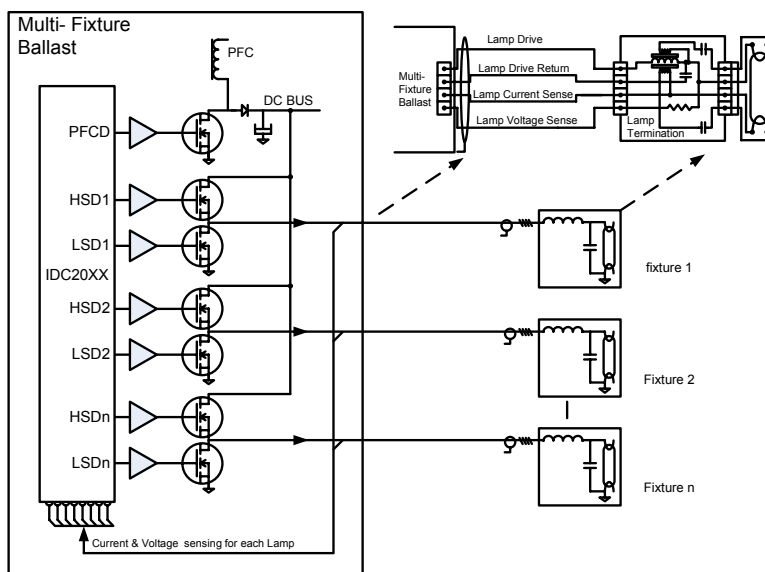

Multi-Fixture Ballast with independent Half-Bridge Topology

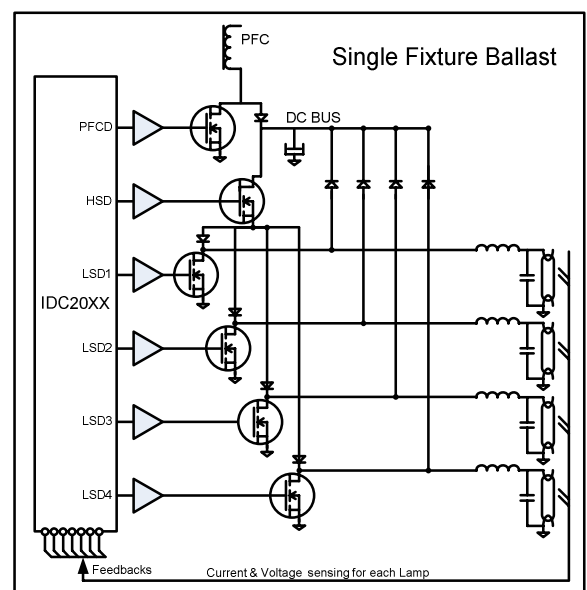

Single Ballast with Common High-Side Power Switch Topology

This patent describes unique topologies that provide full individual control and protection of separate groups of lamps or fixtures with one single chip. These solutions stem from the abilities provided by the IDC digital controller architecture invented by the company and will allow the implementation of innovative multi-lamp fixtures and luminaries systems.

These topologies will allow the implementation of new innovative and superior multi-lamp fixtures with no restriction on lamp type driving including any combination of linear or compact fluorescent, LED or HID – high intensity discharge - lamps, with each lamp individually controllable for Full On or Off or dim.



Lighting control systems using these fixtures will dramatically gain lower installation costs and maintenance fees by extending lamp life thus providing rapid payback while achieving the maximum level of energy savings and enhancing comfort and productivity.

These topologies will provide in addition, effective load shedding that is not available today with the uniqueness of controlling all the elements of the system down to the level of an individual lamp in a fixture.

This patent reinforces Systel's unique position in the market due to the fact that the applications based on this patent are unmatched and linked directly to the company's new generation of IDC controllers whose architecture is also patent protected. We are confident that this patent will boost industry interest in Systel's products and open new frontiers in energy saving solutions.

This patent is a significant addition to Systel's patent portfolio. This additional coverage strengthens Systel's competitive position while fueling potential for OEM relationships across diverse lighting market segments like fluorescent, HID and the promising LED lamp applications

Systel experts invite you to visit them at booth 742 to experience live demonstrations of the revolutionary ballast approach and controls powered by the IDC2000.

About Systel

SYSTEL is a pioneer in mixed-signal power and management developing propriety comprehensive digital based solutions. Its first application in power electronics was in 1993 when it unveiled a true on-line high performance UPS system implementing unique control functions in logic engines. The first generation of its digital power management solution for lighting was unveiled in 1998. Systel holds 8 key patents and has more than 15 patent applications pending that range from core technology (silicon architecture) and power control functions and communication methods to power topologies and building control systems supported by the company's IDC digital SoC controllers that will provide our customers with infringement-free designs.

Press Contact: SYSTEL Development and Industries Ltd.

Lev Hanevet Building, 5 Golda Meir St., Science Park, Nes Ziona, Israel

Phone: +972 (0)8 9313010, Fax: +972 (0)8 9313011, marketing@systel.co.il

More information can be found at Systel's website: www.systelpower.com