



Integrated Digital Control

Application Note:
SYANL108
June 2004

PLC Dimmable Electronic Ballast for 4xT8 32W Lamps. 2 pairs in true parallel connection where each pair is connected in series

Contents:

1. Ballast Characteristics	2
2. Ballast Bill of Materials (BOM)	3
3. Component Notes to Ballast BOM	4
4. PLC Line Coupler (Reference A1 in Ballast BOM)	5
5. Dimmable Electronic Ballast for 4 T8 32W Lamps (2x2)	7
6. PLC Line Coupler Alternative I with Linear Power Amplifier OPA A561	8
7. PLC Line Coupler Alternative II with Class D Power Amplifier based on dual gate driver TC1428, or similar	9

Introduction:

The present document shows a reference design of a networkable electronic ballast for a 4 lamp fixture based on a configuration of 2 pairs of T8 32W lamps in true parallel connection, where each pair is connected in series connection. This ballast is based on the IDC2000 controller and two way controllable by PLC-Link™ power line carrier communication. This application also includes test results of the engineered ballast prototypes, a non-networkable solution and components breakdown given for networkable and non-networkable models.

This application note is an abridged reference design of the ballast described in application note SYANL104-1. Refer to for SYANL104-1 for detailed performances and features of this ballast plus design considerations.

1. Ballast Characteristics

- Optimal preheat & ignition
- Dimmable: 1% - 100% light level
- Fully protected
- 4 lamps in two light channels – each channel can be remotely and independently turned on & off
- Remotely controlled by PLC (option)
- Optimized efficiency at all light levels
- High Power Factor – Low input current THD

Note: The ballast will be non-dimmable without the integration of the line coupler circuit.

The table below describes the ballast performance with 32W T8 lamps

Light level [%]		100	93	86	70	51	30	10	5	1
DC Bus [V]		290	275	270	250	200	190	190	200	260
Input Power [W]	4 Lamps	142.0	133.0	124.0	104.0	80.5	57.5	32.5	27.0	21.0
	2 Lamps	71.5	66.8	62.4	52.8	41.0	28.9	17.3	15.3	11.7
PF		0.99	0.99	0.99	0.99	0.99	0.99	0.98	0.97	0.96
THD [%]		3.80	3.80	3.50	3.00	3.00	3.10	8.00	11.00	15.00
Lamp Voltage [V]		139	141	145	151	160	170	170	162	137
Lamp Current [mA]		215	195	175	137	94	56	21	12	5
Filament [V]		1.85	1.90	2.10	2.50	2.70	3.20	3.50	3.50	3.60
Current Crest factor		1.39	1.35	1.35	1.35	1.35	1.35	1.44	1.55	
Flicker [%]		0.32	0.30	0.30	0.33	0.38	0.22	0.83	1.00	
Ballast Efficacy Factor (BEF)	4 Lamps	0.70	0.70	0.69	0.67	0.63	0.52	0.31	0.19	0.05
	2 Lamps	1.40	1.39	1.38	1.33	1.24	1.04	0.58	0.33	0.09

2. Ballast Bill of Materials (BOM)

Refer to component notes in Section 3

Item	Quantity	Reference	Part
0		A1	PLC Line Coupler (see Note 1)
1	5	C1, C2, C10, C20, C31	0.22UF 400V Met. Polyester (see Note 2)
2	4	C9, C13, C12, C29	1nF 250VAC Y2
3	1	C8	4.7nF 250VAC X2
4	2	C35, C24	4.7nF 1.6KV Met. Polypropylene
5	1	C5	22uF 450V Electrolytic
6	2	C27, C26	100uF 6.3V Electrolytic
7	1	C22	10uF 25V Electrolytic
8	1	C3	22pF 500V
9	6	C14, C23, C28, C34, C36, C54	330nF 50V 10% Ceramic thru hole
10	2	C18, C60	0.47uF 10% 0805
11	14	C4, C6, C7, C19, C30, C43, C44, C49, C61, C63, C65, C66, C67, C68	0.1uF 10% 0805
12	2	C58, C17	10nF 10% 0805
13	2	C80, C85	1nF 10% 0805
14	2	C45, C46	15pF 10% 0805
15	1	C59	100pF 10% 0805
16	1	C62	470pF 10% 0805
17	1	C16	47pF 10% 0805
18	1	D1	MUR460
19	6	D2, D3, D4, D7, D17, D25	HER106
20	1	D37	1N4007
21	1	D24	LM431
22	15	D8, D9, D10, D11, D12, D13, D16, D19, D20, D21, D22, D23, D26, D27, D28	1N914B
23	1	F1	2A
24	2	J4, J5	6 pin lamp connector
25	1	J1	Line input connector
26	1	L1	Diff U125W Core: Micrometals T68-26 (optional for better filtering of input)
27	1	L2	PFCC-U125W Core: EF32
28	1	L3	Comm.Mode U125W Core: EF25
29	2	L5, L4	BAL_S2L Core: EF25
30	2	Q1, Q2	IRF840
31	2	Q4, Q3	IRF830
32	1	Q9	2N2222A
33	1	R2	NTC (see Note 3)
34	1	R1	0.33 1W 1%
35	2	R4, R9	332K 0.25W 1% TH
36	1	R5	20K 0.25W 5% TH
37	1	R11	3.57K 0.25W 1% TH
38	4	R15, R17, R18, R20	100K 0.25W 1% TH
39	9	R21, R23, R24, R26, R30, R33, R34, R35, R39	150K 0.25W 5% TH
40	2	R29, R40	10Ω 0.25W 1% TH
41	4	R3, R8, R13, R38	30Ω 5% 0805

Ballast BOM (cont.)			
Item	Quantity	Reference	Part
42	3	R10, R22, R32	5.1K 5% 0805
43	2	R28, R37	2.7K 5% 0805
44	4	R27, R36, R14, R25	2K 5% 0805
45	2	R31, R53	10Ω 5% 0805
46	2	R19, R46	100K 5% 0805
47	1	T1	Auxiliary PS transformer Core: EF16
48	1	U1	IDC2028
49	1	U4	IR2101S (see Note 4)
50	1	U5	Dual DRV (as TC1411N) (see Note 5)
51	1	U6	TNY253G off-line regulator (see Note 6)
52	1	VR1	Varistor 5J
53	1	V1	Rectifier bridge 600V 4A (or 4X1N5407) (see Note 7)
54	1	Y1	CRYSTAL 12MHz 100ppm
	132	Total components count	

3. Component Notes to Ballast BOM

These notes refer to Section 2 above.

- Item 0 -A1 – Sub-assembly see schematic and BOM options in this document.
- Item 1 -C1 – Filter capacitor 0.22μF and Item 26 -L1 – Line filter differential inductor: **optional** to comply with European standard EN50065 for electromagnetic disturbance.
- Item 33 -R2 – NTC **optional**, added to the circuit to decrease inrush current each time the ballast is connected to the line. This component can be eliminated if the ballast is permanently connected to line.
- Item 49 – U4 – IR2101 High side driver and low side driver for half bridge, made by International Rectifier (IR).
- Item 50 – U5 – TC1411 dual non-inverting low side driver made by Microchip, this item has many replacements from various companies (with gate driver part number ending with 427).
- Item 51 – U6 – TNY253G Off-line regulator for the ballast auxiliary voltages. Chip made by "Power Integrations" and can be replaced by "VIPer12" from STmicroelectronics with slight changes.
- Item 53 – V1 – Power bridge rectifier to be chosen for up to 1.5ARMS continuous input current. The lowest cost solution might be using four 1N5407 diodes.
- Magnetic components: For design examples of the magnetic components see Magnetic Components Specifications of the 125W Ballast in application note SYANL104-1.

4. PLC Line Coupler (Reference A1 in Ballast BOM)

4.1. PLC Line Coupler Alternative I based on OPA561 Linear Power Amplifier from TI. Similar designs can be made using DSL amplifiers. See note to the table below.

Item	Quantity	Reference	Part
1	1	C81	470nF 250VAC
2	2	C79, C77	220uF 16V Electrolytic
3	4	C78, C82, C83, C88	0.47uF 10% 0805
4	1	C84	22nF 10% 0805
5	4	C72, C74, C75, C76	10nF 10% 0805
6	1	C71	3.3nF 10% 0805
7	2	C86, C87	2.2nF 10% 0805
8	2	C80, C85	1nF 10% 0805
9	2	D38, D39	D1N4734A
10	1	L11	200uH Axial Lead 0.25"
11	2	L12, L13	10uH Axial Lead 0.25"
12	2	L14, L15	2mH Axial Lead 0.25"
13	1	R64	1.5K 5% 0805
14	1	R65	2K 5% 0805
15	1	R66	620Ω 5% 0805
16	2	R70, R67	6.2K 5% 0805
17	1	R68	100Ω 5% 0805
18	1	R69	1K 5% 0805
19	1	R71	3K 5% 0805
20	1	R72	18K 5% 0805
21	1	R73	300Ω 5% 0805
22	1	T2	PLCD_Trafo Core: EF16
23	1	U3	OPA561 (TI) (see Note 1)
	36	Total components count	

Note 1:

Item 23 – U3 - OPA 561 is a wideband power amplifier from TI that has the characteristics to make a premium PLC transmitter at the requested frequency band. A good replacement for this component can be one of a large variety of existing DSL amplifiers such as AD8017, AD8019 and AD8391 from Analog Devices or EL1519 from Intersil. Of course the electrical circuit will need to be changed slightly.

4.2 PLC Line Coupler - Alternative II

PLC Transmitter Class D Power Amplifier based on TC1428 or similar dual gate driver.

Item	Quantity	Reference	Part
4	1	C8	22n 250VAC X2
3	1	C7	0.47uF 10% 0805
5	1	C9	100nF 10% 0805
6	1	C10	22nF 10% 0805
7	1	C11	18nF 10% 0805
2	5	C2, C3, C4, C5, C6	10nF 10% 0805
1	1	C1	3.3nF 10% 0805
8	2	D1, D2	1N4744A
9	1	L1	200uH Axial Lead 0.25"
10	2	L3, L2	10uH Axial Lead 0.25"
11	2	L4, L6	68uH Axial Lead 0.25"
12	2	L7, L5	75uH Axial Lead 0.25"
13	1	R1	1.5K 5% 0805
14	1	R2	620Ω 5% 0805
15	1	R3	2K 5% 0805
16	1	T1	PLCD_Trafo Core: EF16
17	1	U1	Dual gate driver (as TC1428) (see note below)
	25	Total components count	

This solution uses a bridge driver made of two complementary drivers: one inverting and one non-inverting (Item 17 U1 TC1428).

5. Dimmable Electronic Ballast for 4 T8 32W Lamps (2x2)

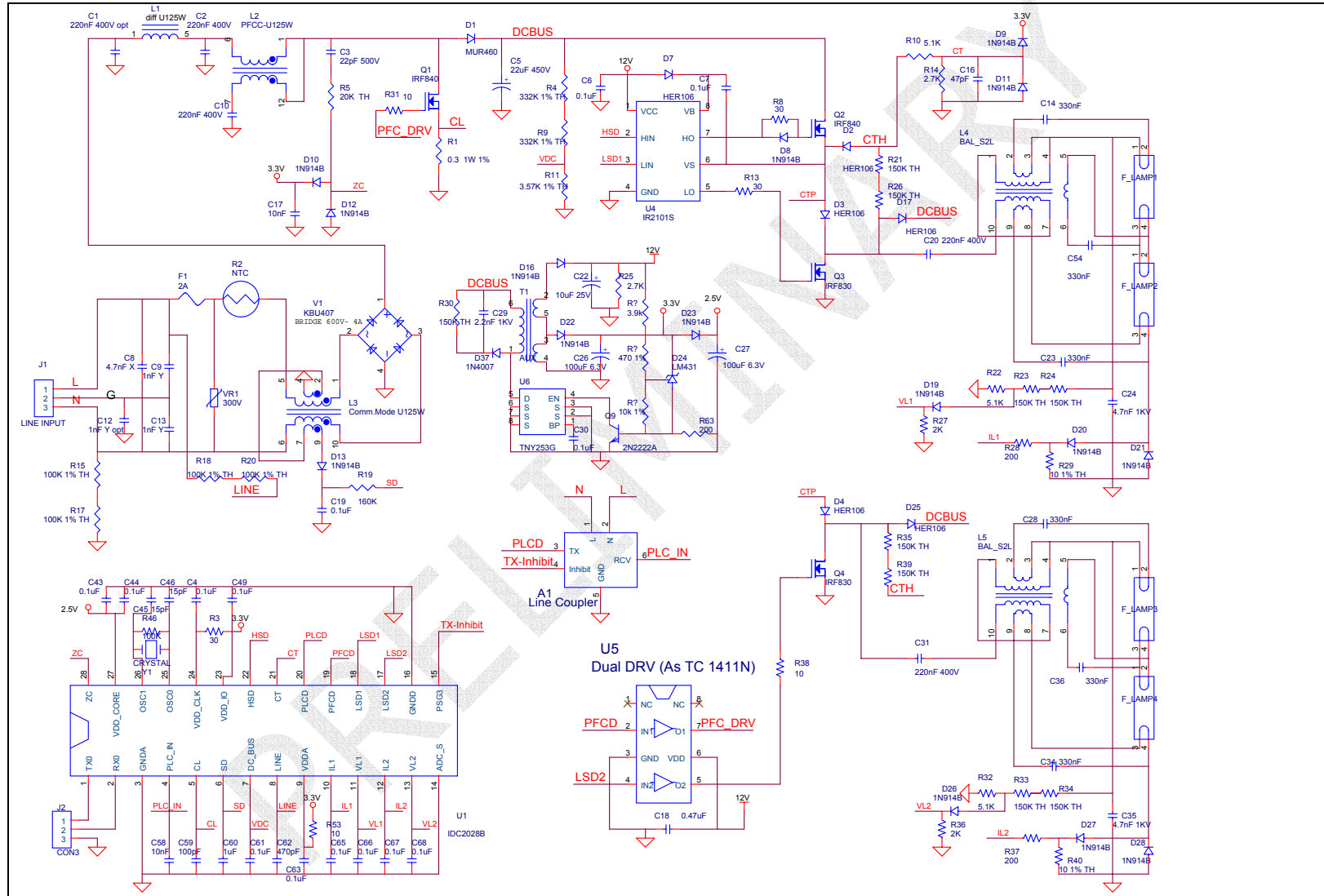

6. PLC Line Coupler Alternative I with Linear Power Amplifier OPA A561

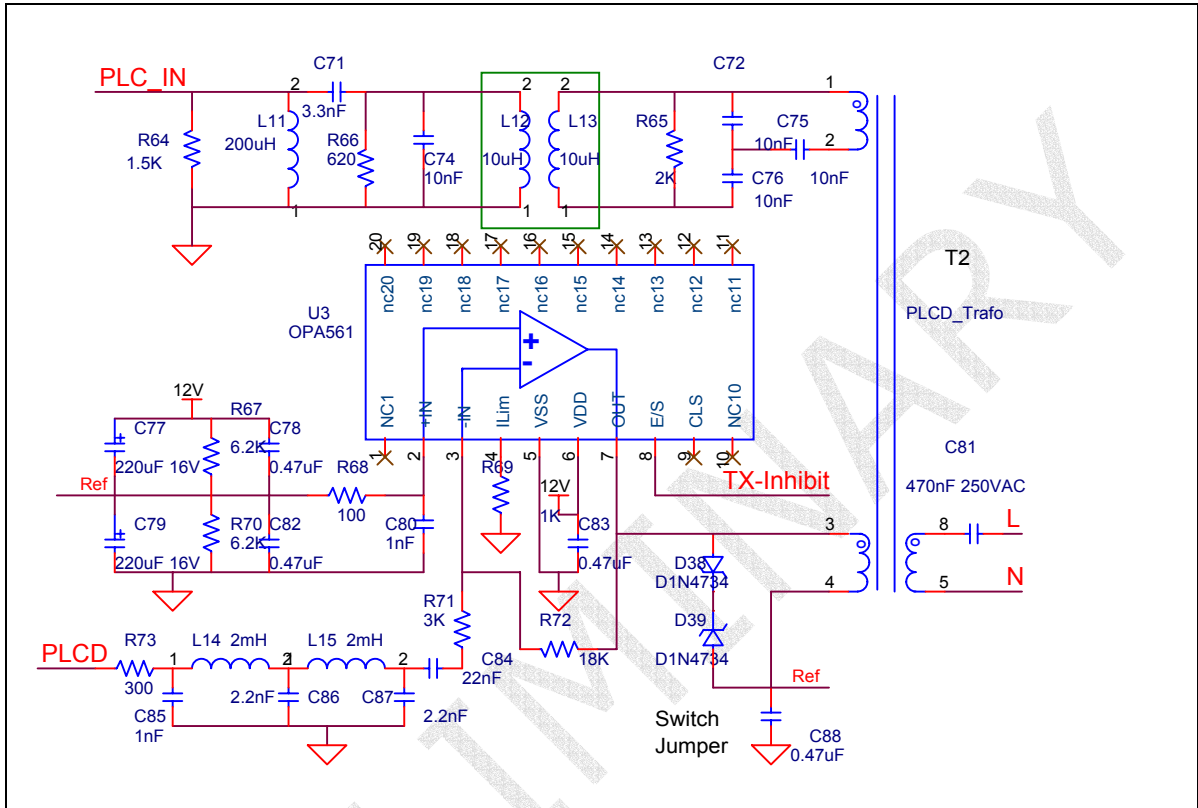

7. PLC Line Coupler Alternative II with Class D Power Amplifier based on dual gate driver TC1428, or similar

